

GE  
Oil & Gas

# oxy.IQ

## Panametrics

### Oxygen Transmitter



#### Applications

An oxygen transmitter for use in:

- Glove box purge and leak detection
- Natural gas
- Semiconductor wafer machines
- Coating process machines
- Membrane air separators
- Inert welding gases
- Pure gaseous hydrocarbon streams
- Process monitoring of gaseous monomers
- Heat treating and bright annealing

#### Features

- Two-wire, loop-powered 4 to 20 mA transmitter
- Display with keypad
- Intrinsically safe option
- Ex flameproof option
- Proven galvanic fuel cell O<sub>2</sub> sensor technology
- User selectable ranges for ppm and percent oxygen
- User-friendly and intuitive user interface with diagnostics
- Microprocessor-based, all-digital technology for reliable operation
- Low maintenance, economical and compact
- Sensor failure output error
- Sensor lifetime indication
- NAMUR error indication



## Panametrics Oxygen Transmitter

The oxy.IQ is a highly reliable and cost-effective two-wire, loop-powered transmitter with a linearized 4 to 20 mA output. It measures oxygen in ten ppm ranges and seven percentage ranges. All ranges are user-selectable. This compact transmitter uses proven sensor technology to accurately measure O<sub>2</sub> in a variety of gases, even in hazardous environments.

### Proven Sensor Technology

The oxy.IQ's oxygen sensor is an advanced galvanic fuel cell that provides superior performance, accuracy, stability and long life. The cell's innovative design eliminates the potential for negative signal output, reduces sources of contamination.

The cell is unaffected by other background gases or hydrocarbons and is compatible with acid gases (OX-2 and OX-4 cells). Recovery from air at low ppm levels takes just a few minutes. Because the cell is self-contained, minimal maintenance is required. There is no electrolyte to change or electrodes to clean.

### Intrinsically Safe

When equipped with optional zener barriers or a galvanic isolator, the oxy.IQ can be mounted in a hazardous (classified) location.



Advanced Galvanic Fuel Cell Sensor

## Control at the Tip of a Finger

The rugged oxy.IQ is controlled by a microprocessor that enables the user to select the range, trim outputs and perform calibration. Improved user interface includes user-selectable and programmable ranges, sensor diagnostics including a sensor lifetime feature and sensor raw signal, low reading/sensor failure signal and temperature compensation. Programming is easily done using the keypad and display. These keypad buttons allow complete functionality in hazardous areas when equipped with a zener barrier or a galvanic isolator per drawing 752-347.

### Installation Flexibility

The compact oxy.IQ, with its built-in microprocessor, is designed to fit easily into any installation site. The oxy.IQ can be installed right at the sampling point, whereas other transmitters must be rack or panel mounted.

### Sample Systems

In addition to standard features and options, GE offers a full line of sample handling systems for a variety of applications. If needed, GE can design and build a sample conditioning system to meet unique application requirements. Please contact GE for details.

## Oxygen Sensor Interference Gases

Gas	OX-1 and OX-5, ppm Cont.		OX-2, ppm Cont.		OX-3, % Cont.		OX-4% Cont.	
	Cont.	Int. (1)	Cont.	Int. (1)	Cont.	Int.	Cont.	Int.
H <sub>2</sub> S	<5 ppm		<10 ppm		0.0005%	0.01%	0.001%	0.1%
SO <sub>3</sub>	<10 ppm		<10 ppm		0.01%	0.1%	0.01%	0.1%
SO <sub>2</sub>	<10 ppm		(3)		0.01%	0.1%	(3)	(3)
HCl	<1000 ppm		(3)		0.1%	1.0%	(3)	(3)
HCN	<1000 ppm		(3)		0.1%	1.0%	(3)	(3)
CO <sub>2</sub>	<1000 ppm		(3)		0.1%	20%	(3)	(3)
NO <sub>2</sub>	(2)		(2)		(2)	(2)	(2)	(2)
CL <sub>2</sub>	(2)		(2)		(2)	(2)	(2)	(2)

Cont. = Continuous, Int. = Intermittent

- (1) Recommended maximum exposure 30 minutes followed by flushing with ambient air for equal period
- (2) Minimal effect on sensor performance, but produces signal interference of 1:2 ratio, ppm levels only. For example, 100 ppm NO<sub>2</sub> looks like 200 ppm O<sub>2</sub>
- (3) Minimal effect on sensor performance

# oxy.IQ Specifications

## Intrinsically Safe (IS) Installation

Intrinsically safe installations require a zener barrier, one IS cable and one non-IS cable.

### Power Requirements

24 to 28 VDC at 50 mA

### Cable

- PN 704-1318: blue jacket, twisted pair with connector; 26 AWG; 2 or 10 m length

### Output

Total load must equal  $250 \Omega \pm 5\%$  when using zener barrier

## General Purpose Installation

Standard option package

### Power Requirements

9 to 28 VDC loop powered, 0.7 W maximum

### Cable

- PN 704-1317: black jacket, twisted pair with connector; 26 AWG; 2 or 10 m length

## All Installations

### Process Wetted Materials

- SS process unit: 316 stainless steel, Viton® O-ring, gold plated sensor electrical contacts and glass

### User-Selectable Measurement Ranges

- PPM sensors:
  - 0 to 10 ppm<sub>v</sub> O<sub>2</sub> (OX-1 or OX-2 only)
  - 0 to 20 ppm<sub>v</sub> O<sub>2</sub> (OX-1 or OX-2 only)
  - 0 to 50 ppm<sub>v</sub> O<sub>2</sub> (OX-1 or OX-2 only)
  - 0 to 100 ppm<sub>v</sub> O<sub>2</sub>
  - 0 to 200 ppm<sub>v</sub> O<sub>2</sub>
  - 0 to 500 ppm<sub>v</sub> O<sub>2</sub>
  - 0 to 1000 ppm<sub>v</sub> O<sub>2</sub>
  - 0 to 2000 ppm<sub>v</sub> O<sub>2</sub>
  - 0 to 5000 ppm<sub>v</sub> O<sub>2</sub>
  - 0 to 10,000 ppm<sub>v</sub> O<sub>2</sub>
- Percent sensors:
  - 0% to 1% O<sub>2</sub>
  - 0% to 2% O<sub>2</sub>
  - 0% to 5% O<sub>2</sub>
  - 0% to 10% O<sub>2</sub>
  - 0% to 25% O<sub>2</sub>
  - 0% to 50% O<sub>2</sub>

### Accuracy

- $\pm 1\%$  of range at calibration point
- $\pm 2\%$  of range at the calibration point for the 0 to 10 ppmv range (OX-1 or OX-2 only)

### Repeatability

- $\pm 1\%$  of range
- $\pm 2\%$  of Range for the 0 to 10 ppmv range (OX-1, 2 only)

### Resolution

$\pm 0.1\%$  of range

### Linearity

- $\pm 2\%$  of range (OX-1, 2, 3, 5)
- $\pm 5\%$  of range (OX-4)

### O<sub>2</sub> Sensor Operating Temperature

32 to 113°F (0 to 45°C)

### Sample Pressure

Vented to atmosphere during operation and calibration

### Atmospheric Pressure Effect

$\pm 0.13\%$  of reading per mmHg (directly proportional to absolute pressure). During calibration, pressure and flow must be kept constant.

### Process Connection

- 1/8 in. NPT inlet and outlet

### Dimensions

4.10 x 2.75 x 2.05 in. (104.1 x 69.9 x 52.1 mm)

### Weight

1.35 lb (612 grams)

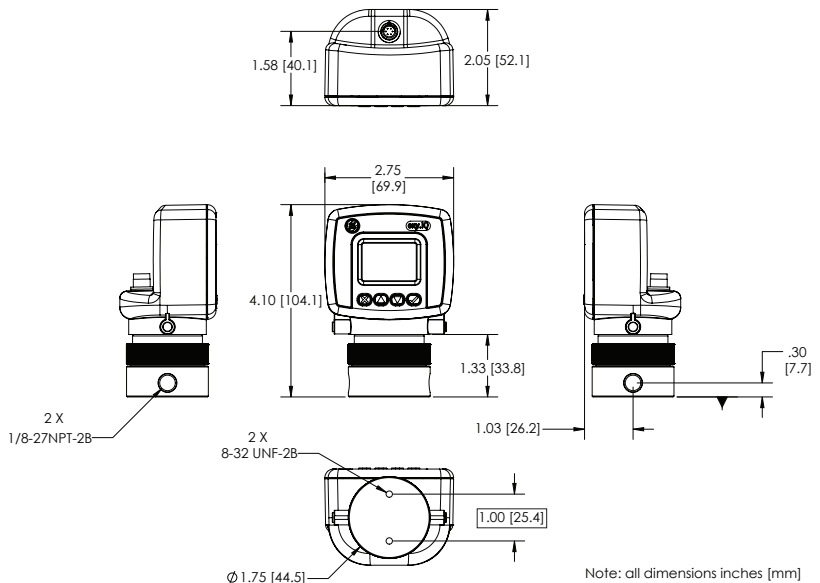

## Sample Flow Rate

1.0 SCFH (500 cc/min) recommended for process units

## Electrical Classification/Certification

Intrinsically Safe

USA/Canada

IS for Class I, Div 1, Groups ABCD, T4

AEx ia IIC T4

ATEX and IECEx

Ex ia IIC Ga T4 Tamb -20 to 60°C

## European Compliance

Complies with EMC Directive 2004/108/EC

## Order and Calibration Information

Record selected option in blank indicated at bottom of form.

OXYIQ BCD-E Option Code

A - Model Only

oxy.IQ Oxygen Transmitter; 4 to 20 mA output

### B - Sensor

- 0 No sensor
- 1 Standard ppm, 0 to 10, 20, 50, 100, 200, 500, 1000 ppm
- 2 Acid ppm, 0 to 10, 20, 50, 100, 200, 500, 1000 ppm
- 3 Standard percent sensor
- 4 Acid percent sensor
- 5 Standard ppm, 0 to 100, 200, 500 and 1000 ppm

### C - Package

- 1 Standard
- 3 Intrinsically safe
- 4 Ex flameproof

### D - Cable

- 0 No cable
- 1 2 meter cable
- 2 10 meter cable

### E - Zener Barrier

- 0 None
- 1 Zener Barrier
- 2 Galvanic isolator

Use this number to order product

### Hazardous (Classified) Location | Non-Hazardous Location

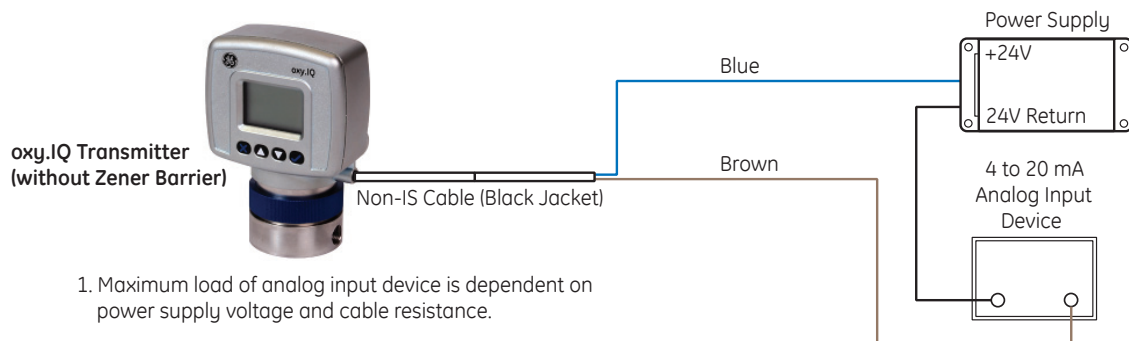
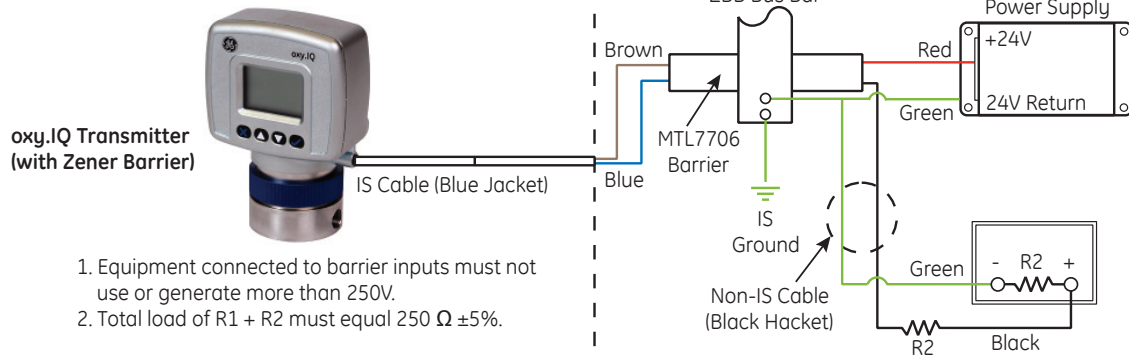

oxy.IQ Installation with Zener Barrier (top) and Installation without Zener Barrier (bottom)



www.gemeasurement.com

920-603C